

SALE

Enfoton Ltd.



Offer for sale

>> In March 2009 Enfoton moves to its state-of-the-art, purpose built, new Factory and Head Office at Kokkinotrimithia Industrial Estate, Cyprus, Europe, with an initial capacity of 60 MW which was soon increased to today's 110MW.

>> ENFOTON SOLAR CAPACITY HISTORY (MW):

- Incorporated in February 2002
- 1MW in 2003
- 60MW in 2009/3 Shifts 5 Days
- 110MW in 2010/3 Shifts 5 Days

Investment is based on German know-how, German technology and strict Quality Control

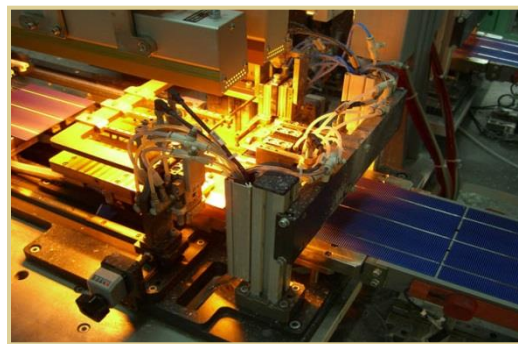

In Process Control-Additional tests during production

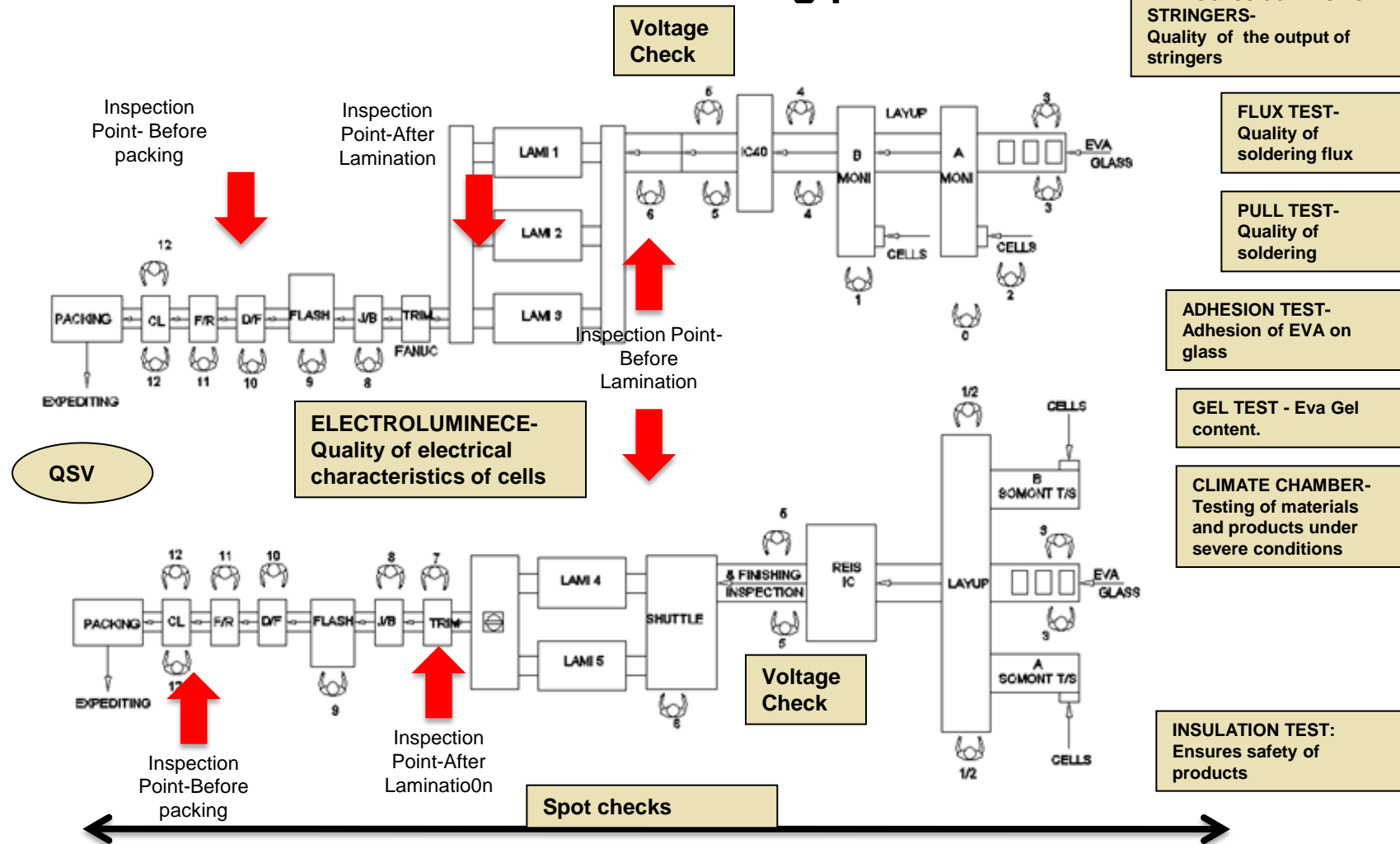

ENFOTON MANUFACTURING PROCESS

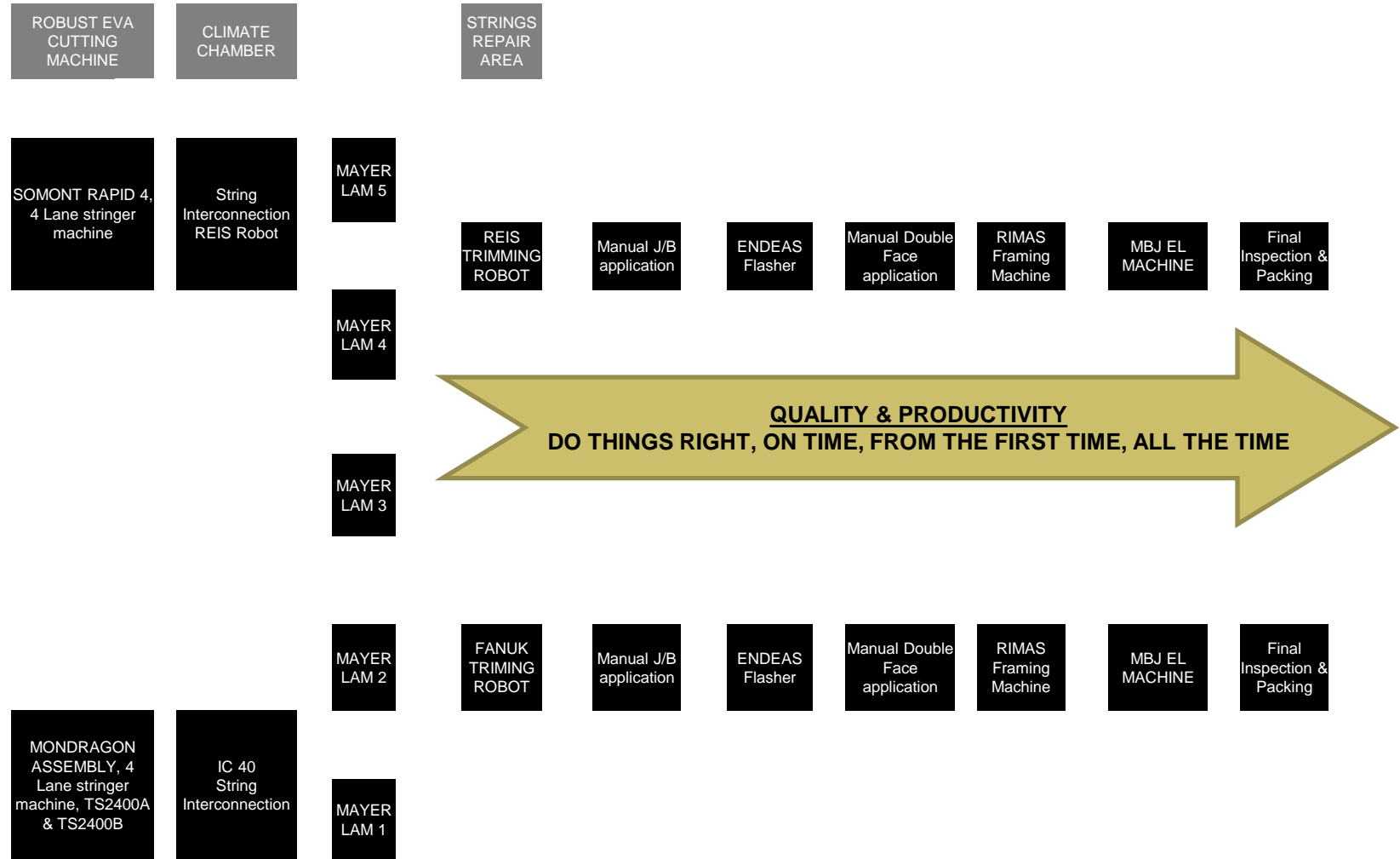

Enfoton Solar photovoltaic panel manufacturing unit is certified with

- >> ISO 9001:2008 - Quality Management System
- >> ISO 14001:2004 - Environmental Management System

And with

- >> OHSAS 18001:2007 - Occupational Health and Safety System



History

Certified Quality

- >> 2010 Quality Management System ISO 9001:2008
- >> 2011 Environmental standard ISO14001
- >> 2011 Work health and safety standard OHSAS18001
- >> 2011 Product certification EN61215:2005
- >> 2011 EN61730:2007 by German TÜV Rheinland
- >> 2011 MCS/BABT UK certification
- >> 2011 Italian Factory Inspection certificate









Angermann & Lüders GmbH & Co. KG

ABC-Straße 35
D-20354 Hamburg

Ansprechpartner:
Herr Timm Langenfeld

T +49 40 355059-126
F +49 40 355059-100
M +49 172 889 41 19

langenfeld@netbid.com
www.netbid.com

Herr Joachim Mink

T +49 40 355059-225
F +49 40 355059-100
M +49 172 755 65 76

mink@netbid.com
www.netbid.com